

CANDLE FILTER (CF)

Standardized series for fully
automatic clarifying filtration

TRANSFORMING
MATERIALS INTO VALUE



VERSATILE PROCESS TECHNOLOGY

Producing clear filtrates.



Precoat filtration

Separating suspensions with low solids content.



Adsorption with activated carbon

Purification of liquids.



Filter cake washing

Single- or multi-stage displacement washing.



Solvent extraction

Filter stripping by applying steam.



Heel filtration

Filtering the entire batch.



Sludge discharge – dry discharge

Application specific integration into the overall process.



PERFECT SOLID-LIQUID SEPARATION

Compact discontinuous filter for high flow rates.

BHS **candle filter** is a discontinuously operating filter. The candle-shaped filter elements are arranged vertically in a pressure vessel. The suspension is guided through filter elements through the applied pressure difference. The filter cake accumulates on the surface of the filter media, and the clear filtrate is discharged upward through the central pipe and the register pipes. The candle filter is a compact unit that operates fully automatically and enables high throughput rates, dry cake discharge and a wide range of cake treatment options.

Filter design

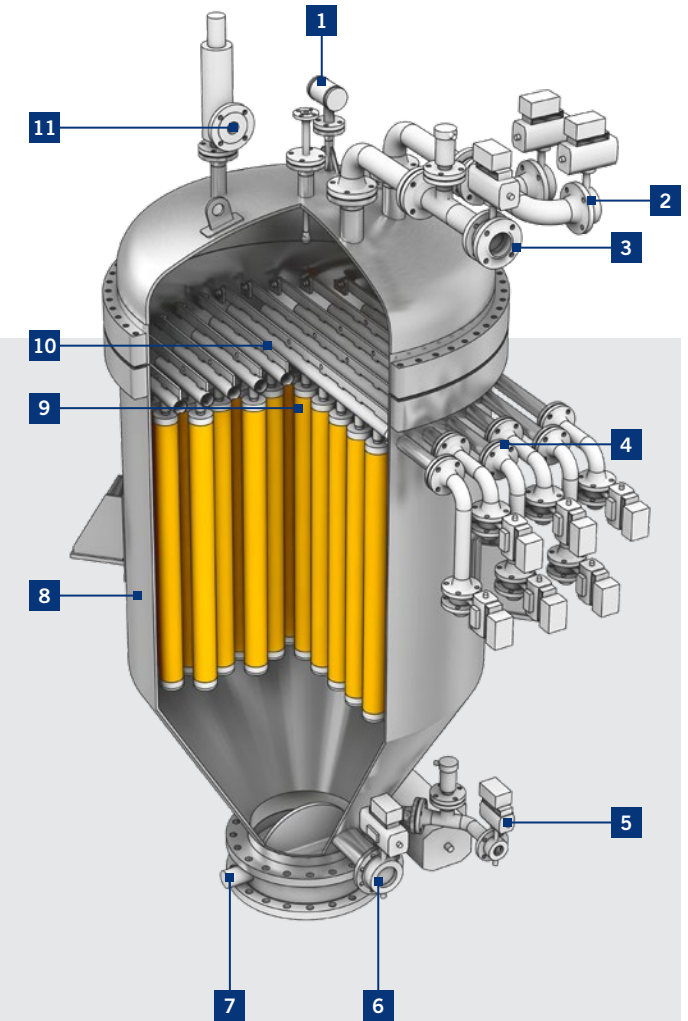

- 1 | Pressure transducer
- 2 | Compressed gas feeding
- 3 | Venting
- 4 | Filtrate discharge
- 5 | Residual volume discharge
- 6 | Suspension feeding
- 7 | Solids discharge
- 8 | Pressure vessel
- 9 | Filter candle
- 10 | Register pipes
- 11 | Safety valve

Advantages

- ✓ Fully automatic operation
- ✓ High plant safety as there are no moving parts
- ✓ Homogeneous cake structure thanks to defined pressure difference
- ✓ Reliable cake discharge

[Further information](#)

www.bhs-sonthofen.com/cf

TOP PERFORMANCE IN EVERY DETAIL

Benefit from superior technology.

HIGH PLANT SAFETY 1

- Gas-tight system
- Differential pressure up to 10 bar g
- Inert or sterile atmosphere

AVAILABLE QUICKLY AND AT LOW COST 2

- Standardized modular system
- Complete piping module
- Can be reconfigured during operation
- Pilot filter available for tests

LOW OPERATING COSTS 3

- Self-cleaning machine concept
- Simple design without moving parts
- Low energy consumption

EFFICIENT FILTRATION PROCESSES 4

- Intelligent control system
- Optimized candle design for maximum cake discharge
- Product-specific filter cloths deliver high separation efficiency of solids

